

## OceanStor Dorado 3000 All-Flash Storage System

### Fast

50% higher performance than the previous generation  
E2E NVMe for 0.05 ms of ultra-low latency  
FlashLink® intelligent algorithms

### Intelligent

Extensive intelligent software features (Smart series)

#### 3-layer management:

- 365-day capacity trends prediction
- 60-day performance bottleneck prediction
- 14-day disk fault prediction
- Immediate solutions for 93% of problems

**FlashEver:** No data migration over 10 years for 3-gen systems

### Simplified

System configuration success in 3 steps and resource readiness in 5 minutes

A-A architecture for non-disruptive upgrade (NDU)

Huawei OceanStor Dorado 3000 is an entry-level storage system in the OceanStor Dorado all-flash series. It leverages an innovative hardware platform, FlashLink® intelligent algorithms, and end-to-end (E2E) NVMe architecture, which combine to deliver a 50% higher performance than the previous generation at an ultra-low 0.05 ms latency. The intelligent algorithms are built into the storage system to make storage more intelligent during the application operations. Furthermore, the all active-active (A-A) architecture and simplified GUI design help simplify Operations and Maintenance (O&M). Excelling in scenarios such as virtualization, OA, and branches, Huawei OceanStor Dorado 3000 is a trusted option for small and medium-sized businesses (SMBs) in the carrier, finance, government, manufacturing, and other fields. The storage system is ideal for IT applications of SMBs with cost-effective services.

## Product Features

### Fast

#### Innovative hardware platform:

The hardware platform of Huawei storage enables E2E data acceleration, improving the system performance by 50% compared to the previous generation.

- √ The intelligent multi-protocol interface module hosts the protocol parsing previously performed by the general-purpose CPU, expediting the front-end access performance by 20%.
- √ The computing platform offers industry-leading performance with 25% higher computing power than the industry average.
- √ The intelligent accelerator module analyzes and understands I/O rules of multiple application models based on machine learning frameworks to implement intelligent prefetching of memory space. This improves the read cache hit ratio by 50%.
- √ The intelligent SSD hosts the core Flash Translation Layer (FTL) algorithm, accelerating data access in SSDs and shortening the write latency by half.
- √ The intelligent hardware has a built-in Huawei storage fault library that accelerates component fault location and diagnosis, and shortens the fault recovery time from 2 hours to just 10 minutes.

## Intelligent algorithms:

Most flash vendors lack E2E innate capabilities to ensure full performance from their SSDs. OceanStor Dorado 3000 runs industry-leading FlashLink® intelligent algorithms based on self-developed controllers, disk enclosures, and operating systems.

## FlashLink®

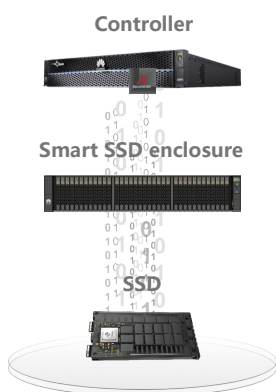

- √ Many-core balancing algorithm: Taps into the full power of the hardware platform in a controller to deliver premium computing power.
- √ Service splitting algorithm: Offloads reconstruction services from the controller enclosure to the smart SSD enclosure, easing load pressure.
- √ Cache acceleration algorithm: Accelerates batch processing with the intelligent module to bring intelligence to storage systems during application operations.

The data layout between SSDs and controllers is coordinated synchronously.

- √ Large-block sequential write algorithm: Aggregates multiple discrete data blocks into a unified big data block for disk flushing, reducing write amplification and ensuring stable performance.
- √ Independent metadata partitioning algorithm: Effectively controls the performance compromise caused by garbage collection for stable performance.
- √ I/O priority adjustment algorithm: Ensures that read and write I/Os are always prioritized, shortening the access latency.

FlashLink® intelligent algorithms give full play to all flash memory and help Huawei OceanStor Dorado achieve unparalleled performance for a smoother service experience.

## E2E NVMe architecture for full series:

All-flash storage has been widely adopted by enterprises to upgrade existing IT systems, but always-on service models continue to push IT system performance boundaries to a new level. Conventional SAS-based all-flash storage cannot break the bottleneck of 0.5 ms latency. NVMe all-flash storage, on the other hand, is a future-proof architecture that implements direct communication between the CPU and SSDs, shortening the transmission path. In addition, the quantity of concurrencies is increased by 65,536 times, and the protocol interaction is reduced from four times to two, which doubles the write request processing. Huawei is a pioneer in adopting end-to-end NVMe architecture across the entire series. OceanStor Dorado 3000 uses the industry-leading 32 Gb FC/25 Gb NVMe protocols at the front end, and 100Gb RoCE protocol at the back end for E2E data acceleration. This enables latency as low as 0.05 ms and 10x faster transmission than SAS all-flash storage.

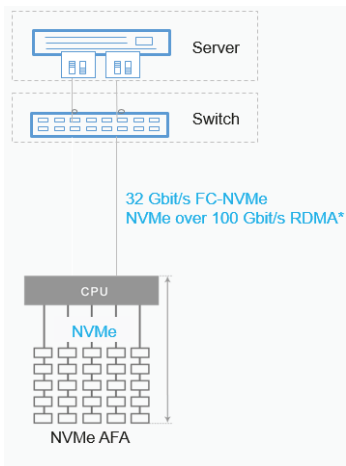

## Linear increase of performance and capacity:

Unpredictability of business growth requires storage to provide effortless linear increases in performance as more capacity is added to keep up with ever-changing business needs. OceanStor Dorado 3000 supports scale-out of 16 controllers, and IOPS increases linearly as the quantity of controller enclosures increases, matching the performance needs of the future business development.

## Intelligent

### On and off-cloud synergy:

Huawei OceanStor Dorado 3000 all-flash system combines general-purpose cloud intelligence with customized edge intelligence over a built-in intelligent hardware platform, providing incremental training and deep learning for a personalized customer experience. The eService intelligent O&M and management platform collects and analyzes over 190,000 device patterns on the live network in real time, extracts general rules, and enhances basic O&M.



**Intelligence throughout service lifecycle:**

Intelligent management covers resource planning, provisioning, system tuning, risk prediction, and fault location, and enables 60-day and 14-day predictions of performance bottleneck and disk faults respectively, and immediate solutions for 93% of problems detected.

**Extensive intelligent software features:**

Thin provisioning and data reduction improve space utilization; intelligent QoS improves service quality; and intelligent heterogeneous virtualization and data migration combine to ensure simplified system lifecycle management.

**FlashEver:**

The intelligent flexible architecture implements component-based upgrades without the need for data migration within 10 years. Users can enjoy latest-generation software and hardware capabilities while also protecting their existing investments.

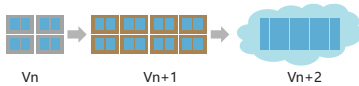
**Simplified****Simple configuration:**

A brand-new graphical user interface (GUI) greatly simplifies the configuration process of traditional storage. This facilitates storage system configuration in just three steps and resource readiness in just five minutes, without assistance from dedicated personnel. This meets the key requirements of SMBs for simple and easy-to-use IT.

**Simple O&M:**

The active-active architecture ensures there is no LUN ownership, meaning a LUN does not belong to any specific controller. In addition, load balancing and non-disruptive upgrade (NDU) are supported. O&M personnel do not need prepare a lot on the host side before an upgrade, greatly improving O&M efficiency.

## Technical Specifications

Model	OceanStor Dorado 3000 V6		
<b>Hardware Specifications</b>			
Maximum Number of Controllers	16*		
Maximum Cache (Dual Controllers, Expanding with the Number of Controllers)	128 GB–1536 GB		
Supported Storage Protocols	FC, iSCSI		
Front-End Port Types	8/16/32 Gbit/s FC/FC-NVMe*, 10/25/40/100 GbE, 25 Gb NVMe over RoCE*		
Back-End Port Types	SAS 3.0/100 Gb RDMA		
Maximum Number of Hot-Swappable I/O Modules per Controller Enclosure	6		
Maximum Number of Front-End Ports per Controller Enclosure	40		
Maximum Number of SSDs	1,200		
SSDs	1.92 TB/3.84 TB/7.68 TB/15.36 TB* palm-sized NVMe SSDs 960 GB/1.92 TB/3.84 TB/7.68 TB/15.36 TB SAS SSDs		
SCM Supported	800 GB SCM*		
<b>Software Specifications</b>			
Supported RAID Levels	RAID 5, RAID 6, RAID 10*, and RAID-TP (tolerates simultaneous failures of 3 SSDs)		
Number of LUNs	8,192		
Value-Added Features	SmartDedupe, SmartVirtualization, SmartCompression, SmartMigration, SmartThin, SmartQoS, HyperSnap, HyperReplication, HyperClone, HyperMetro, HyperCDP, CloudBackup*, SmartTier*		
Storage Management Software	DeviceManager	UltraPath	eService
<b>Physical Specifications</b>			
Power Supply	Controller enclosure: 100V–240V AC±10%, 192V–288V DC SAS SSD enclosure: 100V–240V AC±10%, 192V–288V DC		
Dimensions (H x W x D)	SAS controller enclosure: 86.1 mm x 447 mm x 520 mm NVMe controller enclosure: 86.1 mm x 447 mm x 620 mm		
	SAS SSD enclosure: 86.1 mm x 447 mm x 410 mm NVMe SSD enclosure*: 86.1 mm x 447 mm x 620 mm		
Weight	SAS controller enclosure: ≤ 30 kg NVMe controller enclosure: ≤ 32 kg SAS SSD enclosure: ≤ 20 kg NVMe smart SSD enclosure: ≤ 35 kg		
Operating Temperature	–60 m to +1800 m altitude: 5°C to 35°C (bay) or 40°C (enclosure) 1800 m to 3000 m altitude: The max. temperature threshold decreases by 1°C for every altitude increase of 220 m		
Operating Humidity	10% RH to 90% RH		

\*For further details on specification with an asterisk for a specific project, please contact Huawei sales.

To learn more about Huawei storage, please contact the local office or visit Huawei Enterprise website <http://e.huawei.com>.



Huawei Enterprise Business APP



Huawei IT Products & Solutions - LinkedIn





Huawei IT Products & Solutions - YouTube



Copyright © Huawei Technologies Co., Ltd. 2020. All rights reserved.

No part of this document may be reproduced or transmitted in any form or by any means without prior written consent of Huawei Technologies Co., Ltd.

#### Trademark Notice

 **HUAWEI**, and  are trademarks or registered trademarks of Huawei Technologies Co., Ltd. Other trademarks, product, service and company names mentioned are the property of their respective owners.

#### NO WARRANTY

THE CONTENTS OF THIS MANUAL ARE PROVIDED "AS IS". EXCEPT AS REQUIRED BY APPLICABLE LAWS, NO WARRANTIES OF ANY KIND, EITHER EXPRESS OR IMPLIED, INCLUDING BUT NOT LIMITED TO, THE IMPLIED WARRANTIES OF MERCHANTABILITY AND FITNESS FOR A PARTICULAR PURPOSE, ARE MADE IN RELATION TO THE ACCURACY, RELIABILITY OR CONTENTS OF THIS MANUAL.

TO THE MAXIMUM EXTENT PERMITTED BY APPLICABLE LAW, IN NO CASE SHALL HUAWEI TECHNOLOGIES CO., LTD BE LIABLE FOR ANY SPECIAL, INCIDENTAL, INDIRECT, OR CONSEQUENTIAL DAMAGES, OR LOST PROFITS, BUSINESS, REVENUE, DATA, GOODWILL OR ANTICIPATED SAVINGS ARISING OUT OF OR IN CONNECTION WITH THE USE OF THIS MANUAL.

HUAWEI TECHNOLOGIES CO., LTD.  
Bantian, Longgang District  
Shenzhen 518129, P. R. China  
Tel: +86-755-28780808

[www.huawei.com](http://www.huawei.com)