



AEG

Power Solutions

PROTECT B.

750 bis 3000 VA

Sicherheit für File- und Application Server, Netzwerk Equipment,
Kommunikationssysteme und Prozessleitsysteme

PROTECT B. • Produktübersicht

PROTECT B.

VI - Technologie nach IEC 62040-2 / EN 50091-3

Line - Interactive USV mit Sinus - Ausgang



← 750 / 1000 / 1500 / 2000 / 3000 VA →

AEG

Power Solutions

PROTECT B. • Bedien-Tableau

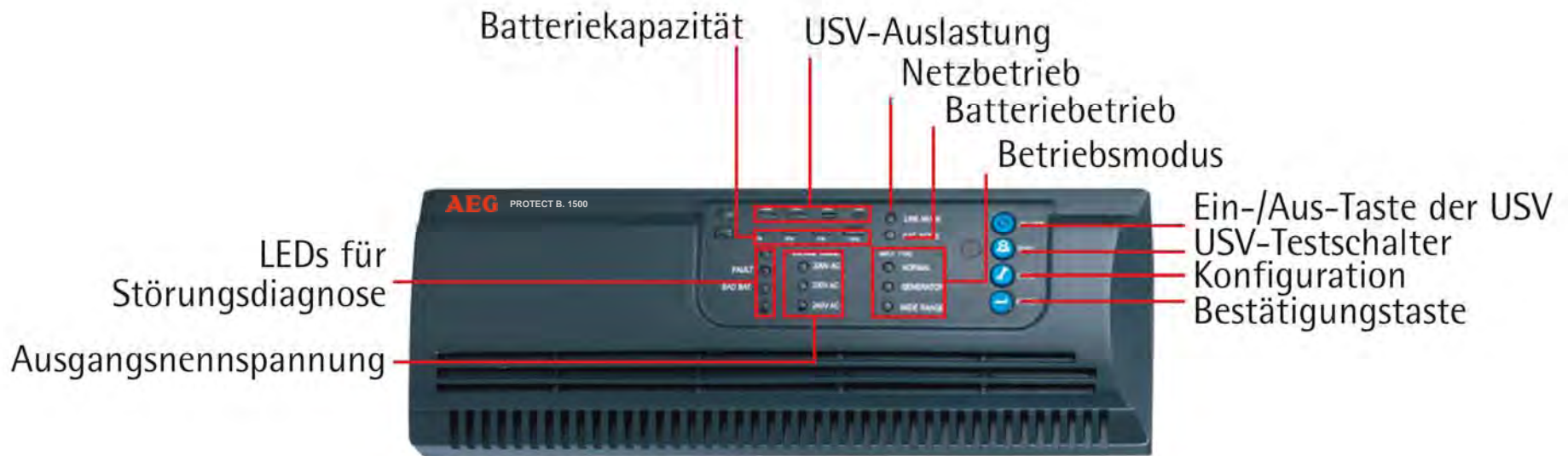

PROTECT B. • Rack - und Tower - Kompatibilität

Flexibel:
Rack & Tower



... Variabel: Montage



PROTECT B.750 & B.1000 • Ausstattungsmerkmale

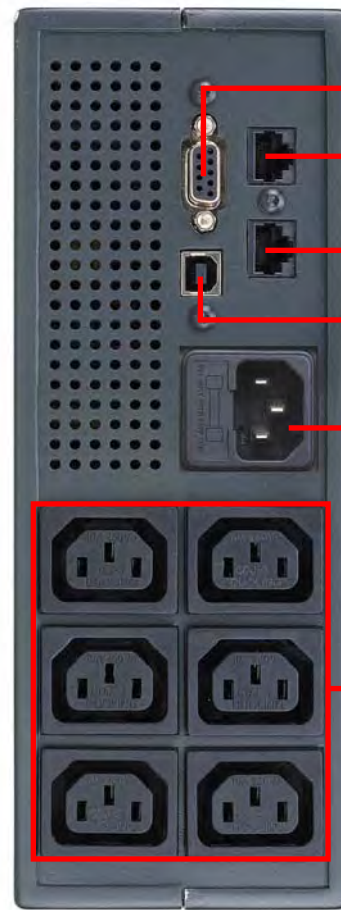

RS232

Überspannungsschutz
Fax, Modem, Netzwerk

USB Port

Netzeingang

USV Ausgang

B. 750 4 x IEC 320 C13

B.1000 6 x IEC 320 C13

PROTECT B.1500 & B.2000 • Ausstattungsmerkmale

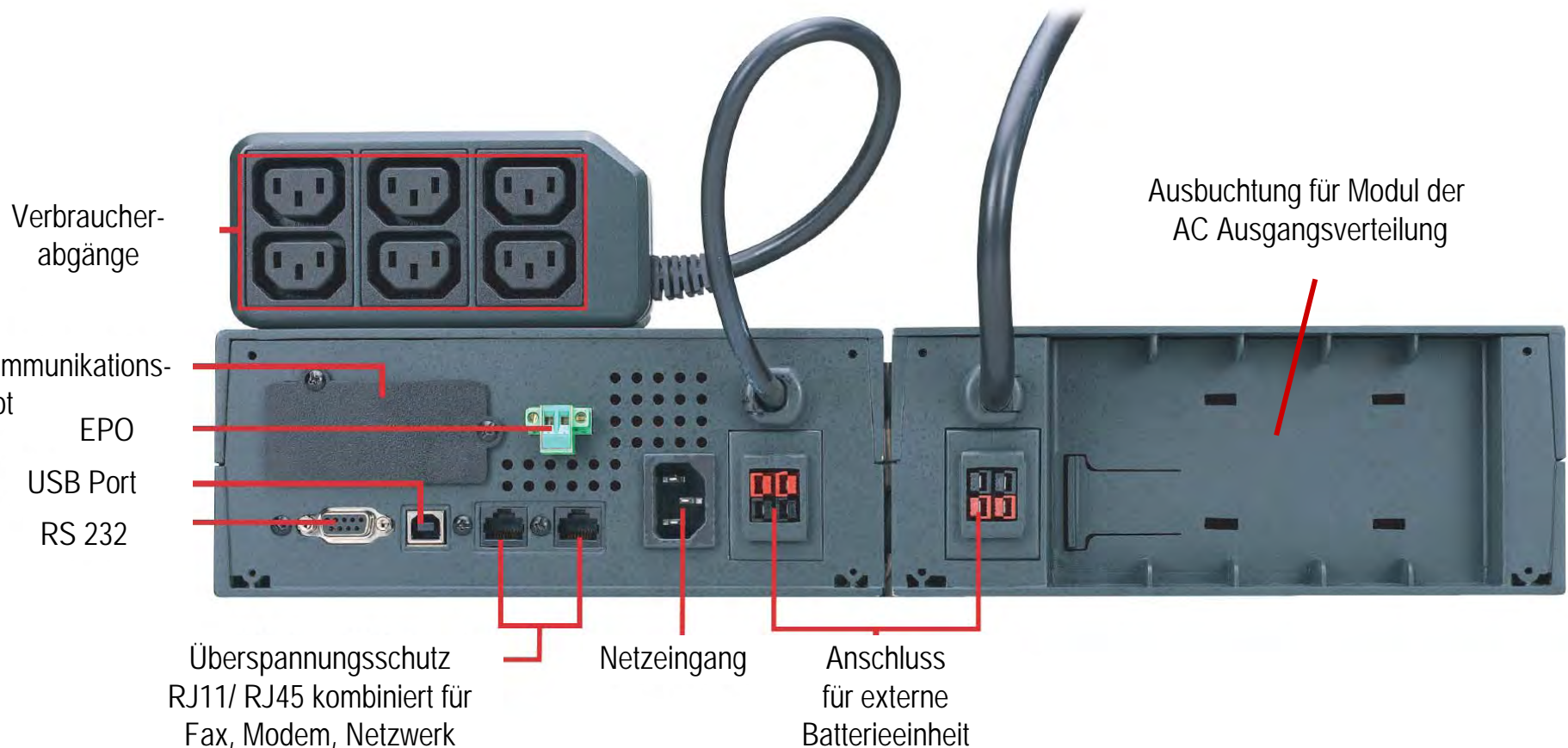

PROTECT B.3000 • Ausstattungsmerkmale

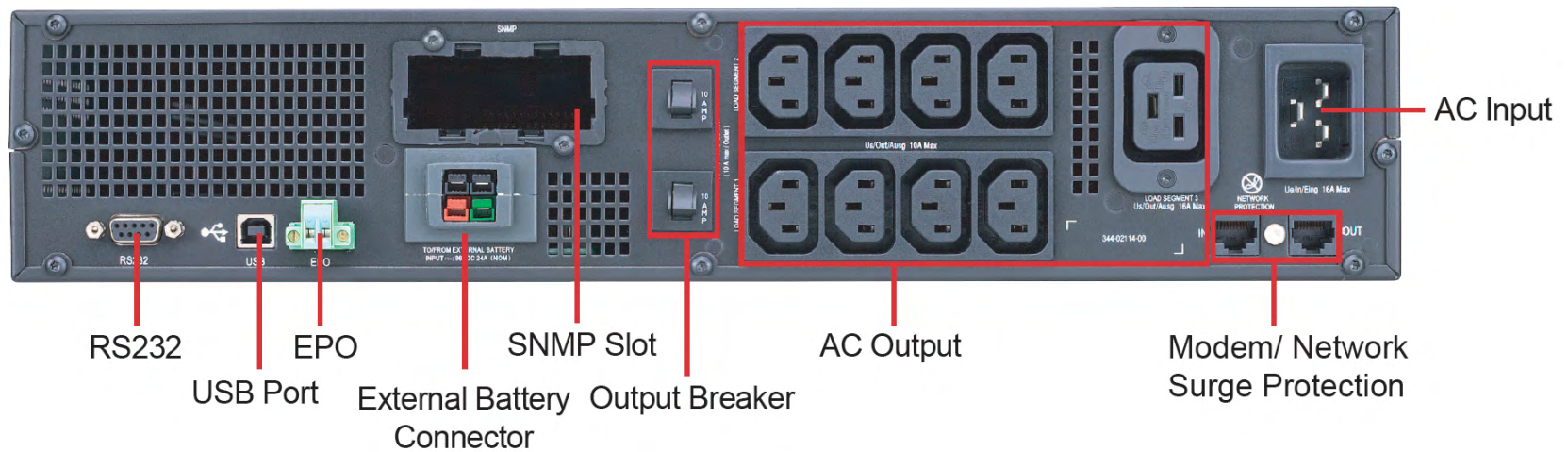

PROTECT B. • Überbrückungszeit bei Vollast

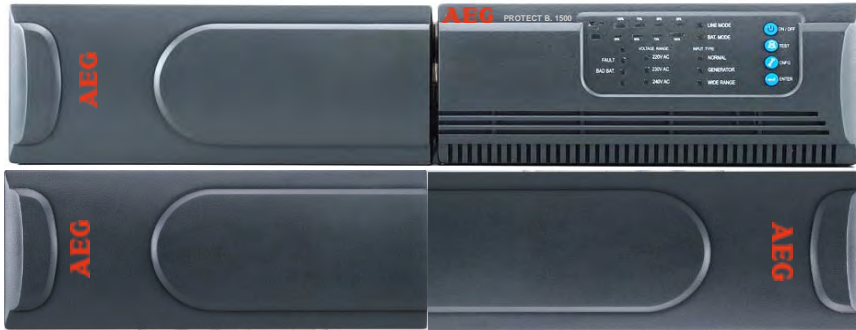

Installation als Rack



Tower Variante

	B. 750	B.1000	B.1500	B.2000	B.3000
Standard	5 min.	5 min.	- - -	- - -	5 min.
+ 1 battery pack	- - -	- - -	5 min.	5 min.	24 min.
+ 2 battery packs	- - -	- - -	15 min.	15 min.	45 min.
+ 3 battery packs	- - -	- - -	30 min.	27 min.	55 min.
+ 4 battery packs	- - -	- - -	50 min.	40 min.	75 min.
+ 5 battery packs	- - -	- - -	65 min.	50 min.	- - -

PROTECT B. • Überbrückungszeit im Detail

	100W	150W	250W	500W	750W	1000W	1250W	1500W	1750W	2000W
PROTECT B. 750	60	37	16	5						
PROTECT B.1000	60	41	22	8	5					
PROTECT B.1500 + 1 x B.1500BP	148	95	48	17	8	5				
PROTECT B.1500 + 2 x B.1500BP	300	200	110	48	26	15				
PROTECT B.1500 + 3 x B.1500BP	480	300	180	84	48	30				
PROTECT B.1500 + 4 x B.1500BP	700	450	240	110	70	50				
PROTECT B.1500 + 5 x B.1500BP	> 10 h	540	300	150	90	65				
PROTECT B.2000 + 1 x B.2000BP	148	95	48	23	12	8	5			
PROTECT B.2000 + 2 x B.2000BP	300	200	120	50	29	23	16			
PROTECT B.2000 + 3 x B.2000BP	480	300	180	90	50	35	28			
PROTECT B.2000 + 4 x B.2000BP	>10 h	450	240	110	77	52	41			
PROTECT B.2000 + 5 x B.2000BP	>10 h	540	300	150	100	69	52			
PROTECT B.3000	180	120	76	35	22	14	10	8	6	5
PROTECT B.3000 + 1 x B.3000BP	>10 h	480	180	120	76	56	46	35	28	25
PROTECT B.3000 + 2 x B.3000BP	> 20 h	> 10 h	400	210	130	90	76	60	54	48
PROTECT B.3000 + 3 x B.3000BP	> 20 h	> 20 h	> 10 h	300	190	140	110	86	69	60
PROTECT B.3000 + 4 x B.3000BP	> 20 h	> 20 h	> 10 h	400	250	190	140	120	100	82

PROTECT B. • Lieferumfang

- inkl. komplettem Leitungsset:
 - Netzanschlussleitung,
 - 2 Geräteanschlusskabel
 - USB und RS232 Kommunikationsleitungen
- Shutdown- and Management Software CompuWatch inkl. 5er Netzwerklizenz
- Mehrsprachige Betriebsanleitung (deutsch/englisch liegt in gedruckter Form bei)

